

# Colum/WTLC

## 3-Way Speaker

### SPECIFICATIONS

#### ACOUSTIC & ELECTRICAL SPECIFICATIONS:

- **Nominal Impedance:** 6 ohms
- **Power Rating:** 20-200 watts per channel RMS
- **Crossover Freq.:** 500Hz (mechanical)  
2000 Hz, 8000 Hz
- **Frequency Response:** 35Hz-28kHz +/-4dB
- **Wave Transmission Line Tweeter Dispersion:** 3 steradian above 8 kHz

#### PHYSICAL SPECIFICATIONS:

- 1x - Tweeter #902-0122, Substitute #902-2213
- 1x - Tweeter Walsh #902-0060
- 1x - Woofer #902-2121, Substitute #902-2666.
- **Dimensions:** 41"H x 11"W" x 11"D  
104.2cm(H) x 28cm(W) x 28cm(D)
- Cabinet Not Sold
- Grille NLA
- Crossover NLA
- Logo #716-0136

#### PRODUCTION HISTORY

- Introduced in 1976
- Discontinued 1981
- Original Retail Price: \$658.00

### TECHNICAL INFORMATION

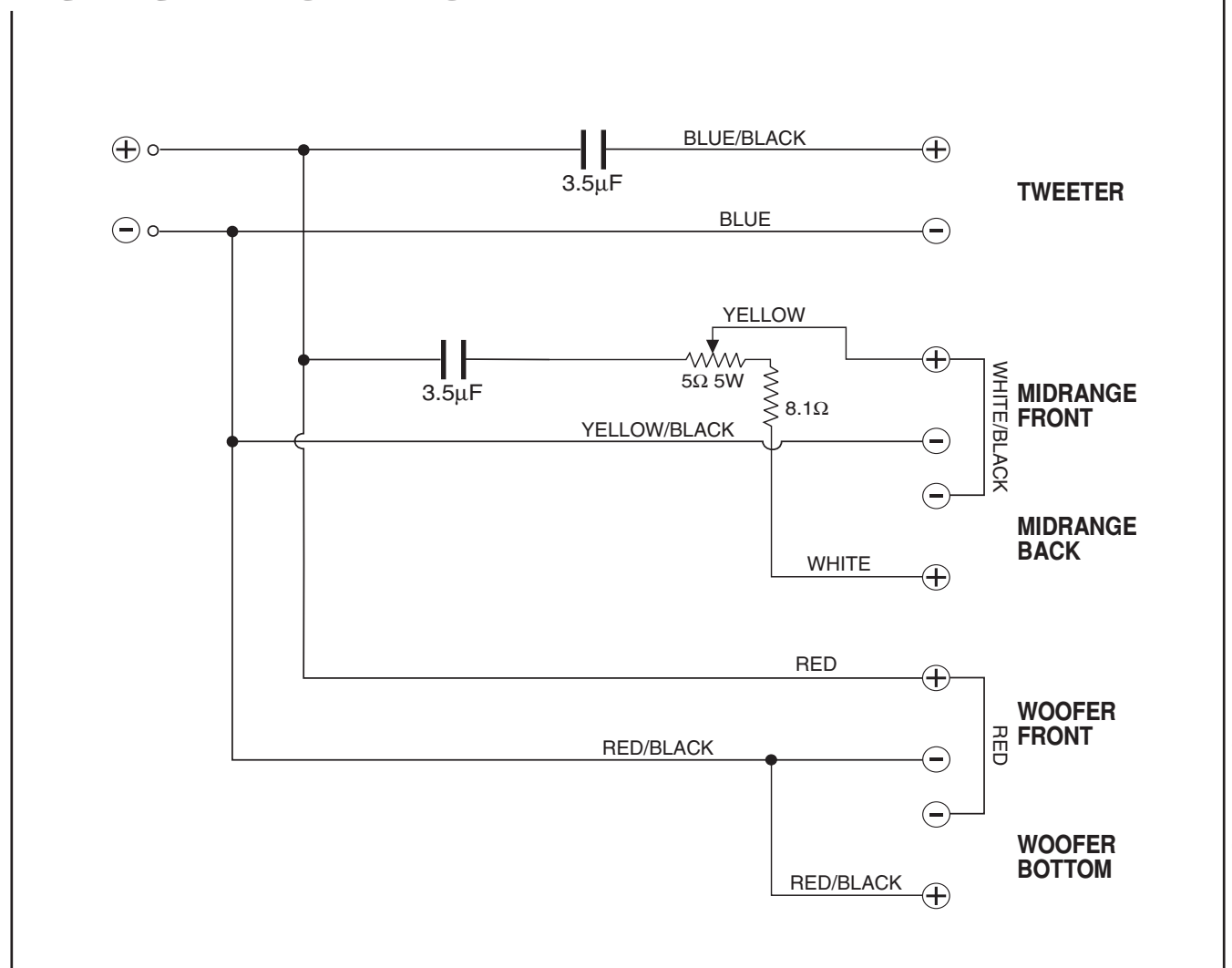

Colum/WTLC 3-Way Speaker